

DIMENSIONS (CU-HD1300FT)

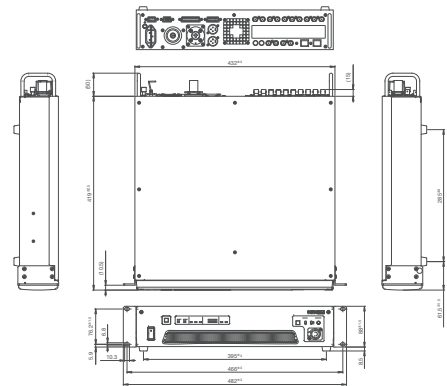

DIMENSIONS (CU-HD550)

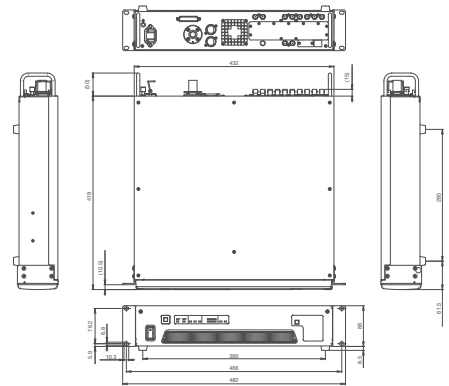

DIMENSIONS (HDF-700H-S1)

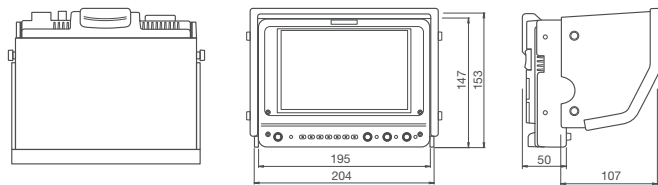

DIMENSIONS (SU-1000)

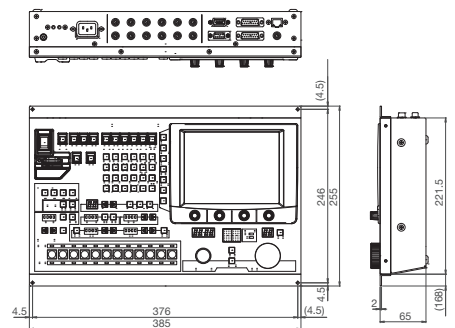

DIMENSIONS (RU-1000VR)

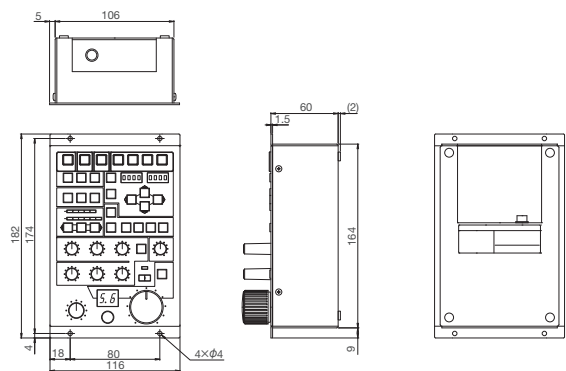

DIMENSIONS (SA-1100)

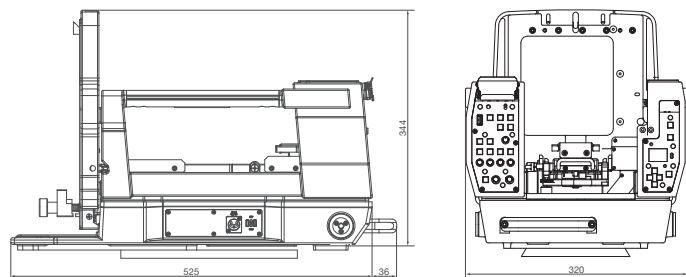

All other trademarks are the property of their respective owners.

CAUTION : To ensure safe operation, please read the instruction manual before using this product.

KOKUSAI DENKI Electric Inc.

URL : <https://www.kokusaidenki.co.jp/global/en/index.html>
32, Miyuki-cho, Kodaira-shi, Tokyo 187-8511, Japan
Phone : +81-42-322-3111, Fax : +81-42-322-3303

KOKUSAI DENKI Electric Asia Pte. Ltd.

URL : <https://www.kokusaidenki.com.sg>
9 Tampines Grande, Asia Green, #02-00,
Singapore 528 735
Phone : +65-6911-6794

KOKUSAI DENKI Electric America, Inc.

URL : <https://www.kokusaidenki.us>

Headquarters
104 Feeding Hills Road Southwick, MA 01077, U.S.A.
Toll Free : +1 (833) 227-1658,
Phone : +1 (669) 207-5038

West Office
11258 Monarch Street, Unit H
Garden Grove, CA 92841, U.S.A.

West Sales Phone : +1 (516) 682-4448
East Sales Phone : +1 (516) 682-4445
Midwest Sales Phone : +1 (516) 682-4450

KOKUSAI DENKI Electric Europe GmbH

URL : <https://www.kokusaidenki.eu>

Frankfurt Head Office
Siemensstr. 9, D-63263 Neu-Isenburg, Germany
Phone : +49 (0) 6102-8332-0, Fax : +49 (0) 6102-8332-499

London Office
Orion House, Bessemer Road, Welwyn Garden City, Herts,
AL7 1HH, UK
Phone : +44 (0) 7808 330195

KOKUSAI DENKI Electric Linear S/A

URL : <https://www.kokusaidenki.com.br>
Avenida Frederico de Paula Cunha, 1001 - Maristela
Santa Rita do Sapucaí - MG - Brasil - CEP: 37540-000
Phone : +55 (35) 3473-3473, Fax : +55 (35) 3473-3474

KOKUSAI DENKI

Multi-Format Digital HDTV Production Camera SK-HD1800



HDTV Broadcast, field and studio camera with HDR, up-sampled 4K SDI and video over IP.



KOKUSAI DENKI's SK-HD1800 broadcast studio and field production camera is a full-featured, uncompromising system that meets the most demanding studio and field applications. It incorporates a new generation of high-performance, 2/3-inch, Global Shutter, CMOS, Full Frame sensors. The SK-HD1800 delivers 1080 progressive image acquisition, processing, transmission and outputs throughout the entire camera chain.

Regardless of your cabling choices, KOKUSAI DENKI provides full progressive transmission over Single-mode fiber, SMPTE Hybrid fiber or Triaxial cables. The SK-HD1800 retains all the popular functions and features of the existing KOKUSAI DENKI SK broadcast camera line-up. As an option, signal delivery is now available with SMPTE 2110 compliant network connections for implementation in hybrid (SDI or, IP) facilities.

High Dynamic Range (HDR) for HDTV production is fully exploited in the SK-HD1800 camera system and is included as standard. HDR is available in two world-wide standards; Hybrid-Log Gamma (HLG) or Perceptual Quantization (PQ/ SMPTE 2084). HDR delivers a dramatic improvement in picture reproduction when viewed on a compatible monitor or TV.

The KOKUSAI DENKI SK-HD1800 system camera optionally features a high-quality 3840 X 2160 UHD signal synthesized from the fully-progressive camera system. This 4K signal is available with Fiber or Triax cable transmission in the CU-HD1300 series CCUs that works with all our progressive camera systems.

High-performance starts with advanced sensors

KOKUSAI DENKI has achieved a new level of HD camera performance with a new generation of CMOS Full Frame progressive scan imagers. Using these newly developed progressive scan CMOS imagers, the SK-HD1800 easily handles difficult mixed frequency LED lighting and display situations.

The new sensors also enable the SK-HD1800 to achieve outstanding resolution, dynamic range, sensitivity and absence of vertical smear. A high horizontal resolution of 1000TVL (Luminance channel) offers very high picture sharpness with low noise and ultra-low vertical smear.

Dynamics headroom ready for today's HDR

The SK-HD1800 takes full advantage of the increased dynamic range output performance of the NEW Global shutter CMOS imagers and the widened spectral response of the optical system. A wider exposure latitude is now available to capture the most challenging scene and lighting conditions which is especially important when applying modern HDR (High Dynamic Range) workflows.

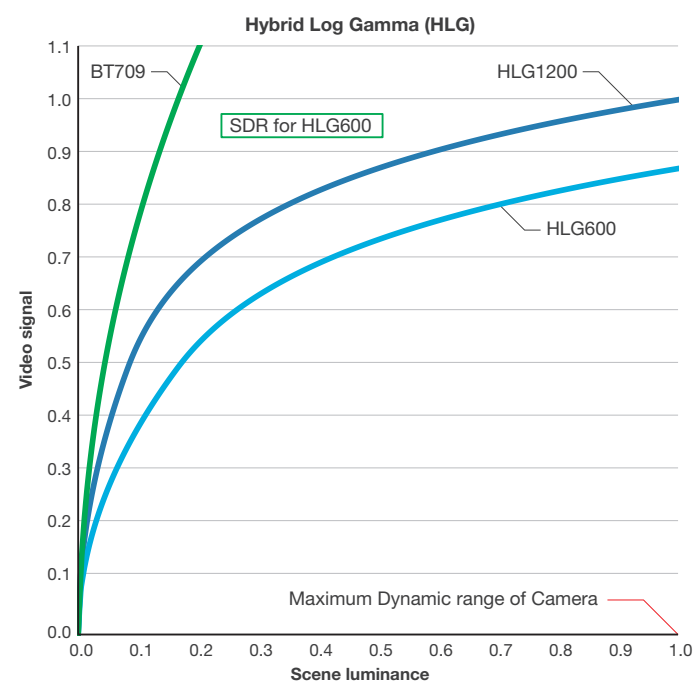

Digital progressive signal transmission via Hybrid Fiber optic cable

The SK-HD1800 camera system utilizes Broadcast-industry professional (SMPTE-304M HFOC) Hybrid Fiber Optic Cable connectors made of high-strength stainless steel. These connectors can be mated end-to-end to extend the camera system's usable cable length and its fiber ends are easily cleaned.

Camera power and cable condition supervision are also performed when using the Hybrid Fiber-Optic Cable (HFOC). With the 1300-series CCUs, the maximum HFOC length with applied camera power and fully operational facilities is over 4,000 meters* (>13,123 feet*).

*The maximum HFOC distance depends on the system configuration.



Superb High Definition picture reproduction & enhancement tools

High Dynamic Range (HDR)

With HLG-600/1200 and HPQ HDR functions in the SK-HD1800 series camera system, you'll see deeper blacks, increased detail in mid-tones, brighter highlights and vivid colors; all resulting in a dramatic improvement in picture quality easily visible at all viewing distances. HDR is available as standard on 2K and 4K SDI outputs on the CU-HD1300/ CU-HD550 series CCUs.



Selectable gamma tables

In addition to normal gamma point and balance adjustments, the SK-HD1800 offers a multi-point gamma table that provides the user with exposure control over just the darkest points in the image. It enables adjustment of the initial gamma gain to optimize the reproduction of dark scene components. KOKUSAI DENKI's DSPs assure that no additional noise components are introduced in the image even with the most aggressive Gamma Table settings. Additionally, this function does not change any of the other parameters of the video signal thus maintaining overall exposure, detail, color reproduction and composition.



Ultra Gamma

Seven different ultra-gamma responses are pre-programmed to dramatically increase the exposure latitude of the camera in high contrast or difficult shooting lighting conditions. These can be used to match the KOKUSAI DENKI camera video to camcorders and cameras of other brands.

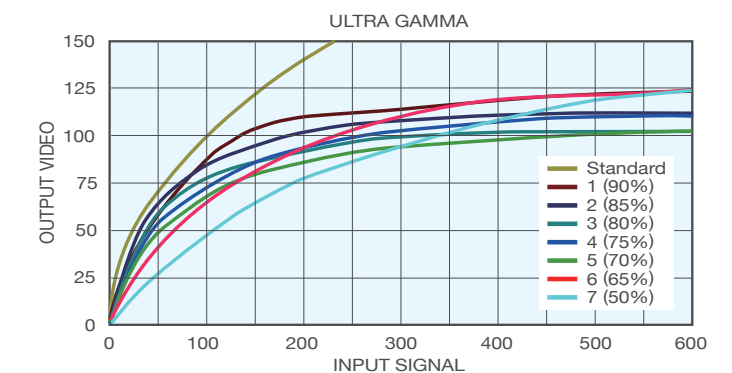

Black stretch and Black press

The SK-HD1800 black stretch/ press function allows better reproduction of dark or underexposed areas by raising or lowering the luminance response of dark zones in the image without changing the black, master gamma, white clip or knee settings. It is especially useful in high contrast image venues, outdoors or sports production.

HDTV Lens optimization

Real-time Lens Aberration Correction (RLAC)

Modern HDTV lenses can still produce optical distortions. One of these called "lateral chromatic aberration" can be reduced in certain lens models when used with the SK-HD1800 camera system. The KOKUSAI DENKI RLAC (Real-time Lens Aberration Correction) function dynamically enhances images using correction data provided by the lens through a digital interface with the camera. This corrective action takes place as the lens zoom, focus and iris are operated.



Gray-Scale automatic setup

The SK-HD1800 offers through-the-lens Gray-Scale Automatic Set-up function to optimize the complete image reproduction system. Video parameters like Gain, Gamma, and Flare are the video signal functions that could vary from lens to lens are consistently corrected accurately.

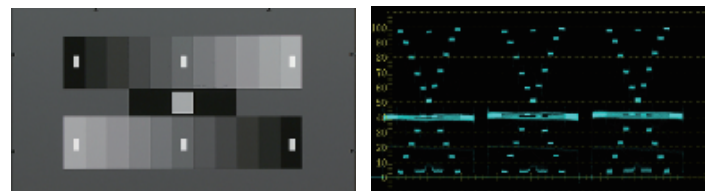

Automatic setup of vertical and horizontal modulation shading

The SK-HD1800 assures that with any lens used, an even, white balance throughout the raster will be attained by the automatic vertical and horizontal modulation shading correction function. At the simple push of a button, this function provides correction for and stores 8 separate individual memories of lens' modulation shading characteristics for the X1 and X2 lens extender positions.



Image reproduction excellence

Triple-masking

The triple-masking functions include the 12-vector, linear matrix and Skin-tone masking to provide the user flexible color control. The 12-vector color corrector provides independent control of the hue and saturation for six primary and six secondary combinations of colors. The 12-vector, linear matrix and Skin-tone masking provide overall color control providing the user with excellent and precise color rendition.



Preset Masking

With KOKUSAI DENKI's preset masking selection, various image color spaces such as STANDARD (KOKUSAI DENKI standard), ITU-709, SMPTE-240M, SMPTE-WIDE, NTSC, and EBU can be used for instant color-matching between cameras. The preset values can be offset to taste or need via menu.

Skin-tone masking

The Skin-tone masking function provides "fine painting" (hue and saturation) of Skin tones without affecting other colors in the scene. This function is additional and independent from the linear matrix and 12-vector-masking functions thereby adding an additional third color correction tool.



Lens Files

The SK-HD1800 can store 8 lens files which include various lens correction data such as vertical modulation shading. This lens correction data can also be stored in a card (SD card), where it can be recalled as needed.

Chroma Saturation

In addition to the extensive color controls offered in the SK-HD1800, the overall color saturation can be varied to taste.

Knee Saturation

The Knee Saturation function restores color saturation to scene highlights above a certain video level. Color saturated objects or skin-tones lost in overexposed scenes are now accurately captured.

Auto-knee

The auto knee provides the perception of a wider dynamic range by dynamically compressing (varying knee and slope) the video level in accordance to the strength of its over-exposure.

Picture sharpness enhancement

Absolute detail control

KOKUSAI DENKI provides 3 major detail controls designed to precisely place, control and shape the picture sharpness characteristics of the SK-HD1800.

Skin-tone Detail

The Skin-tone Detail functions allow a skin-tone color-based softening of the image to achieve the impression of more youthful TV personalities.

Two individual memories exist as well as a function to automatically detect the hue, saturation and luminance of the Skin-tone to be affected. This function is not limited to Skin-tones only; it can increase or decrease the sharpness of any pair of colors in the image. Furthermore, the Skin-tone Detail level can be adjusted to follow the lens zoom position so that a natural overall enhancement is realized at wide angle shots of the talent.

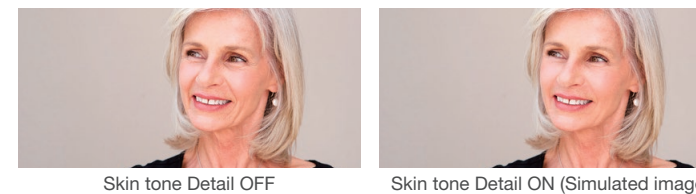

Master Detail items

Master Detail items are available to adjust varied parameters of the detail signal to taste or to achieve a desired "look" in your productions. Some of these adjustments are; H/V detail, crisp, level dependence, knee detail, limiter, source, frequency and balance.

High-chroma detail

The High-chroma detail adjustments allow precise control of the detail level in highly color-saturated portions of the picture such as the petals of a rose or a colorful fabric.



Optical and image capture functions

Versatile Global Shutter CMOS functions

The SK-HD1800 camera system has six PRESET electronic shutter speeds, for stopping action or fast-moving objects in the image, 1/100, 1/125, 1/250, 1/500, 1/1000, 1/2000 (1080/59.94i), plus LOCK SCAN to capture non-synchronous displays without flicker. Automatic Electronic Shutter (AES) maintains the video level when the maximum F-stop shooting condition is reached.

Programmable Smooth Video Gain

This new function allows the SK-HD1800 to smoothly and seamlessly transition between the video gain settings and electronic color correction filters. Continuous recording can be achieved without flash or glitch artifacts in the image.

Optical filters

A servo-controlled, 4-position optical filter wheel is provided as standard. The positions can be memorized in scene files and selected locally by the camera person or remotely from any control surface. The filters provided are: Clear, 4-point Cross, 1/16ND and 1/64ND. All optical replacement filters can be purchased and installed by your KOKUSAI DENKI representative.

ECC (Electronic Color Compensation)

Due to the wide gain characteristics of the SK-HD1800, the ECC function compensates for color temperature electronically by providing preset gains to equal color temperature gradations of 3200K, 4300K, 5600K, 6300K and 8000K. The ECC can be selected locally or by any remote-control unit.

The filter selection can be stored in the Scene files and its status can be displayed on the view finder and the monitor output.

Viewfinder Focus Assist

Three different visual aids are available to help the camera person find the right focus: VF DTL, VF PEAKING and VF Focus Assist. The Area Marker detects edges inside area, while a focus indicator shows the actual detail level by a horizontal line. A Focus Indicator Gauge can further be set to lock the maximum achieved level for a few seconds.

Quick-focus function for Precise Focus

The Quick Focus function automatically opens the iris then sets the video level with the electronic shutter at the push of a button. The resulting shallow depth of focus, allows the camera person to set the exact focus with ease.

AES Automatic Exposure System

The AES provides a fully automatic exposure system allowing unattended image capture from dusk to dawn. Gain, lens iris, ND filter, real-time auto white and variable shutter work in conjunction to maintain 100 video level under uncontrolled lighting such as when reproducing outdoor observation images. The feature can be remotely activated and stored in scene files.

Multi-Format Digital HDTV Production Camera SK-HD1800

Ease of use characteristics & functions

Programmable soft-switches (CS-1, CA-CS)

The camera person can assign Zebra, marker, VF Detail, Quick Focus or FAW to the CS-1 switch via the operation menu. The CA-CS switch can take on the functions of VF Detail on/off, marker-1 or marker-2 on/off.

Viewfinder markers & functions

The SK-HD1800 provides an excellent range of viewfinder markers and functions to aid the camera person obtain outstanding results during a TV program production. All VF marker & personal preference parameters can be stored in 4 dedicated memories for different camera person, programs, shooting conditions or events. These settings can be shared or moved to different cameras with a simple SD card thus saving setup time. Some of the programmable functions include; color/mono, detail, crisp, safety zone, 2 movable markers, center cross-hair, 2 movable effects boxes, variable aspect ratio side panels, side panel contrast/bright, 2-mode zebra and variable line display level polarity.

Viewfinder status displays

Iris F-stop, Lens Extender position, Shutter speed, Optical and ECC filter in use, and Gain setting are all independently displayed via menu selection. Menu selection also includes over-level or between-range zebra pattern.

Camera head inputs & outputs

The camera head provides (2) HD-SDI outputs, (1) SD analog and (1) HD teleprompter out, (1) HD-SDI switchable as Monitor or VF and RET video output via BNC connectors. The MIC-1 channel is switchable with balanced XLR input connector located at the front of the camera (shotgun mic) or at the rear of the CA-HF1300. All the microphone inputs provide phantom power supplies and accept mic or line levels.

These IOs satisfy a wide variety of production requirements and are typically provided with broadcast-grade cameras.

Servo-motor, remotely controlled, filter wheel

The SK-HD1800 camera head offers remote and local control of the 4 position ND filter wheel. Any control panel has access to the filter selection. A Star Filter is provided as standard, but all filters can be easily exchanged through the lens mount.

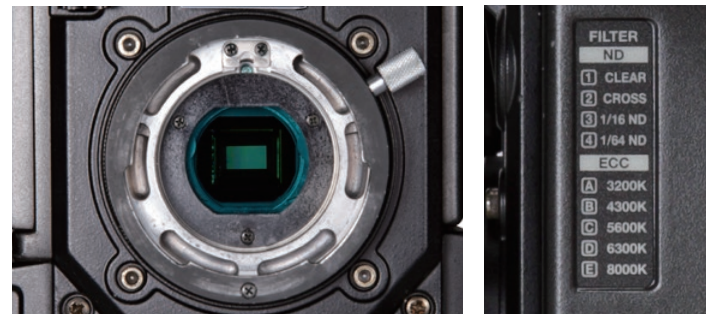

Prompter video / power, auxiliary returns

Both SDI and Analog prompter video are available simultaneously.* Up to 6 SDI returns can be input on CU-HD1300FT-S1 / CU-HD1300F-S1 for selection or output at the camera head.* Red/Green tally commands, Prompter and floor monitor AC power is provided on the cable adaptor.

* (option)



A SCRIPT LAMP port is provided with 12VDC and can power wireless MIC transceivers or Intercom auxiliary units. RET CONT allows switching of SDI AUX video on the VF when the camera is used on a Crane.

Digital progressive signal transmission with Single-Mode fiber optic cable

HDTV camera systems use SMPTE-311M type Hybrid Fiber Optic Cable (HFOC) therefore can also use common Single-Mode duplex (FO) fiber cable typically found in modern wiring infrastructures. All KOKUSAI DENKI HDTV and UHD cameras can use Single Mode (SM) duplex FO without additional or external equipment or special adaptors. The cable operation mode is selectable via a Menu.

Due to KOKUSAI DENKI's power supply design, all KOKUSAI DENKI camera heads (head and cable adaptor "CA") can be operated with an AC or DC power supply. The maximum cable distance with SM FO cable is 10,000 meters or >32,800 feet.

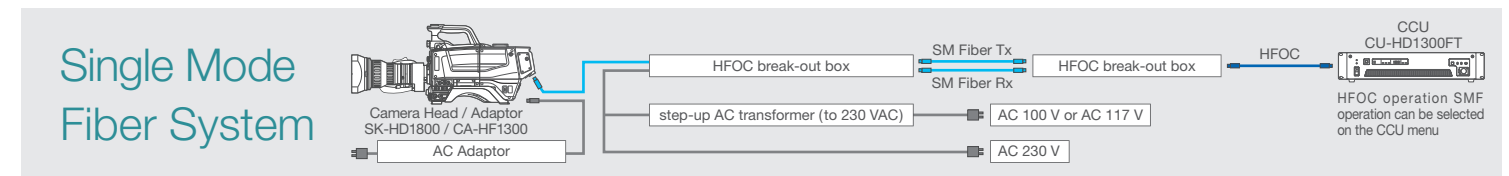

Digital progressive signal transmission with TRIAXIAL copper cable

KOKUSAI DENKI's R&D and expertise in digital transmission enables the offering of the progressive digital triaxial cable system. This new digital transceiver offers video quality visually equivalent to that of a fiber-optic system.

This (3G) digital triax is fully compatible with all KOKUSAI DENKI progressive and interlaced camera heads. Due to its high quality and bandwidth, it preserves HDR as well as the HD-SDI signals used for up-scaling to 4K (UHD) inside the 1300-series CCU.

Optional Model CU-HD1300FT-S1

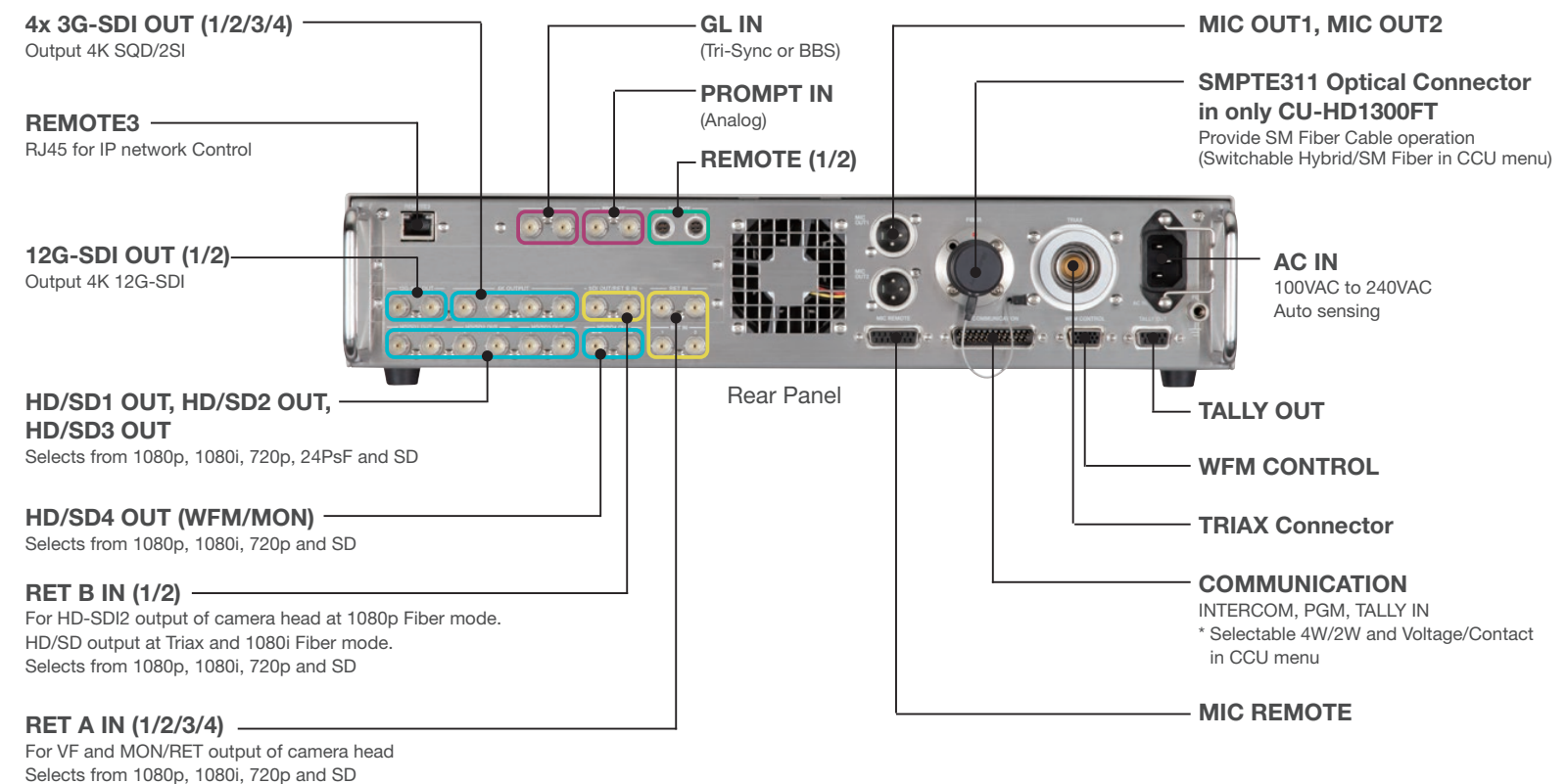

Flexible Choice of Camera Control Units

CU-HD1300 series –

- Simultaneous HDR/ SDR outputs
- 4K(12G+Quad3G) SDI output is optionally available (S1)
- Triax and/or both fiber & triax CCU are also available.
- MoIP (ST-2110 Video over IP) is optionally available (S4)

Please choose CU-HD550 in case of using KOKUSAI DENKI 1080i camera.

CU-HD550 series –

- Cost-effectiveness
- Full HD 1080p or 1080i is available,
- Simultaneous HDR/ SDR outputs
- 4K(12G) SDI output is optionally available (S1)

Please choose CU-HD1300 in case of requiring 2-channel, 2W/4W intercom system and/or analog prompter output.

CU-HD550 Camera Control Unit

The new CA-HF550 and CU-HD550 camera accessories are compatible with all KOKUSAI DENKI 1080p and 1080i Z and SK-series HDTV cameras. See chart below.

The new progressive-scan models can combine with KOKUSAI DENKI 1080p60-native studio and field production cameras to create a fully-progressive 1080p60 system. This includes the global-shutter models Z-HD5500 and the SK-HD1800 cameras. This provides camera system with fully-progressive signal paths for maximum visual quality.

The CU-HD550/CA-HF550 combination offers a lower-cost entry point to full-progressive production for customers who don't require the advanced options and extra I/O connections of the CU-HD1300 CCU series.

The fiber-connected CU-HD550 combines SDTV I/O and multi-format HD SDI inputs and outputs with intercom, return video, teleprompter, tally and remote control interfaces in a heavy-duty 2RU form factor. An RJ-45 network port enables IP-based control, including integration with Ross Video's Open DashBoard control platform. An optional CCU with 12G SDI, 4K/UHD output with simultaneous SDR and HDR is available as model CU-HD550-S1.



CU-HD550 Front Panel



CU-HD550 Rear Panel (Fiber)

CA-HF550 Camera Head Adapter

The CA-HF550 is compatible with the new CU-HD550. See chart below. The CA-HF550 transmits video, audio, power and control over SMPTE 304M fiber between the camera and CCU.

Two HD-SDI connections on the CA-HF550 provide video output at the camera end and can be switched between camera, prompter and return video. The CA-HF550 also provides ample AC power at the camera head to drive both a prompter and floor monitor through the hybrid fiber cable.



CA-HF550
Camera Head Adapter
Side Panel



CA-HF550
Camera Head Adapter
Rear Panel

System configuration chart

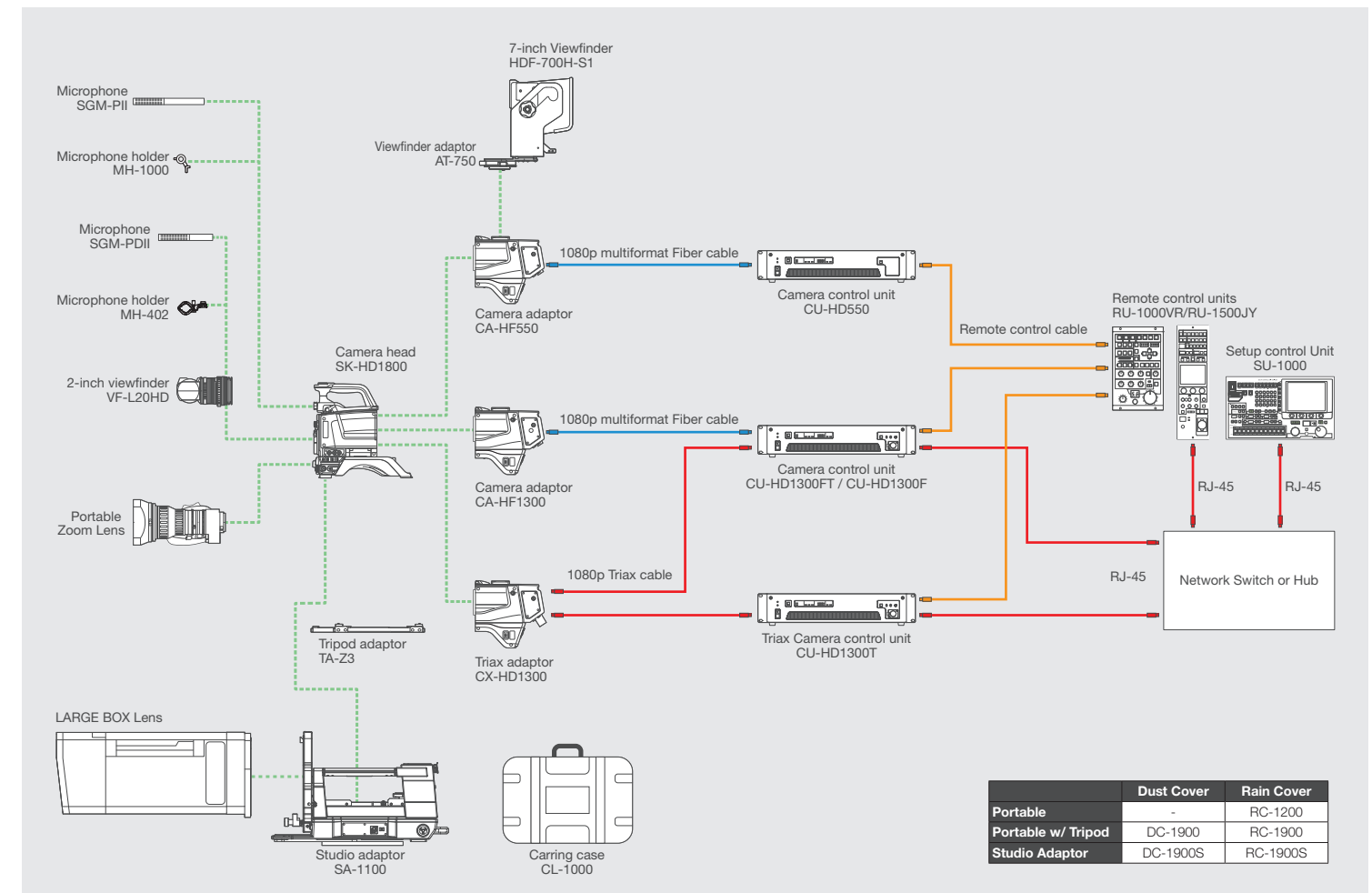

Large lens adaptor

The SA-1100 serves primarily as a mechanical large lens supporter and it also offers these important features: the ability to use "Hanger-type" box lenses and "Bayonet-type" hand-held portable lenses without removing the camera from the actual SA-1100.

Functions routinely required by the camera person in Studio and Field production are brought out from the camera menu and presented in the SA-1100's rear operation panel for easy access.



SPECIFICATIONS

Multi-Format Digital HDTV Production Camera SK-HD1800

Camera Head SK-HD1800

Model name	SK-HD1800 (59.94Hz) , SK-HD1800E(50Hz)
Image sensor	2/3-inch equivalent, CMOS image sensor Effective pixels 1,920 (H) x 1,080 (V)
Native Scan	1080/59.94p, 1080/50p
Prism	F1.4
Optical Filter	1x motorized filter wheel ND(CLEAR, CROSS, 1/16 ND, 1/64 ND)
ECC	3200 K, 4300 K, 5600 K, 6300 K, 8000K
Lens mount	B4 Bayonet
HD Resolution	1000TVL
HD SNR	62 dB
Sensitivity	1080/59.94p, 59.94i : F10 @ 2000 lx, 3200 K, 89.9% reflectance 1080/50p, 50i : F11 @ 2000 lx, 3200 K, 89.9% reflectance
Minimum illumination	2 lx (at F1.4, GAIN: +24 dB)
Vertical Smear	No smear
Gain selection	L (low) -6/-3/0dB M (medium) 0/+3/+6/+9/+12/+15/+18/+21dB H (high) +3/+6/+9/+12/+15/+18/+21/+24 dB
Shutter	Preset mode 1/100, 1/125, 1/250, 1/500, 1/1000, 1/2000 second (59.94Hz) 1/60, 1/125, 1/250, 1/500, 1/1000, 1/2000 second (50Hz) Lock scan mode 1/60.37 to 1/1987 second (59.94Hz) 1/50.36 to 1/2025 second (50Hz) AES mode Automatic video level control by shutter speed.
Geometric distortion	Negligible (excluding lens characteristics)
Registration Overall	0.01 % (excluding lens characteristics)
Dimensions	133(W) x 191(H) x 262(D) mm
Power supply voltage	DC 12 V (10.5 V to 17 V)
Temperature range	Operation -10 °C to +45 °C , 14 °F to +113 °F Storage -20 °C to +60 °C , -4 °F to +140 °F
Power Consumption	20W Head only (without VF)
MASS	approx. 2.1 kg, 4.6 lbs, Head only (without VF)
Input & Output	MON/VF/RET OUT: BNC x 1, HD-SDI REMOTE: 4-pin Multi connector for remote control panel VF: 20-pin Multi VF connector LENS: 12-pin Multi LENS connector MIC: 3-pin XLR MIC-1 connector SD Memory Card Slot

Triax Camera Adaptor CX-HD1300

CCU connector	1x-Triax connector
Video transmission system	Fully digital bi-directional, 10-bit, 4 : 2 : 2 sampling, 3G (1080p50/59.94)
Intercom	2x channel, 5-pin each XLR, MIC on/off, ENG/PD level control, Tracker level control
Program audio	2x, PGM audio level controls w/ Chnl1 & Chnl2 intercom mix
Teleprompter power output	1x 5-pin, 230 VAC, 60 W to 100 W, external prompter Tally drive out (depending on configuration accessories)
Microphones	Chnl1 & 2, Line or MIC level select (MENU), with +48 V phantom power on/off
Return/ Aux switcher	Remote AUX / VF video select connector (RET control)
Video Inputs & Outputs	2x HD-SDI1/3 OUT, 3G-SDI/HD-SDI • 3G-SDI (1080p50/59.94): SMPTE424/425 Level-A • HD-SDI (1080i50/59.94): SMPTE292M 1x HD-SDI2 OUT 3G-SDI or HD-SDI • 3G-SDI (1080p50/59.94): SMPTE424/425 Level-A • HD-SDI (1080i50/59.94): SMPTE292M 1x SD analog prompter out shared with Genlock in
Other I/O	1x 29-pin (for SA-1000 cable-less interface) (female) 1x 5-pin script lamp +12 VDC (1.0 A max) (female) 1x 6-pin VF AUX return (female) (for use in cranes or extended Head / VF configurations) 1x XLR 4-pin, 12VDC power input (male)
Dimensions	142 (W) x 188 (H) x 202 (D)
Mass	2.6 kg, 5.7 lbs. approx.
Operating Temperature	-10 °C to +45 °C, +14 °F to +113 °F

Fiber Camera Adaptor CA-HF1300

CCU connector	1x-type HFOC female connector (LEMO) SMPTE-304M-type
Intercom	2x channel, each XLR 5-pin, channel selection, MIC on/off, volume
Program audio	2x, PGM audio level controls w / Chnl1 & Chnl2 intercom mix
Teleprompter power output	1x 5-pin, AC230 V, 100 VA, external prompter R/G Tally drive out (depending on configuration accessories)
Microphones	Channel 1 & 2 Line or MIC level select (MENU), with +48 V phantom power on/off
Return/ Aux switcher	4-input remote AUX / VF video select connector (RET control)
Video Inputs & Outputs	1x 3G HD-SDI OUT, 1X SD analog teleprompter out shared with Genlock in, 1x HD-SDI RET OUT
Other I/O	1x 29-pin (for SA-1100 cable-less interface) (female) 1x 5-pin script lamp DC12 V (1.0 A max) (female) 1x 6-pin VF AUX return (female) (for use in cranes or extended Head / VF configurations) 1x XLR 4-pin, DC12 V power input (male)
Dimensions	133 (W) x 189 (H) x 194 (D) mm
Mass	2.2 kg, 4.8 lbs. approx.
Operating temperature	-10°C to +45°C, 14°F to 113°F

Camera Control Unit CU-HD1300FT / CU-HD1300F / CU-HD1300T

GENLOCK IN	1x BNC • B-BST 0.45Vp-p/75Ω (loop through) • HDTV tri-level sync 0.60Vp-p/75Ω (loop through)
RETURN IN (1/2)	2x BNC, 3G-SDI/HD-SDI(1080i or 720P)/ SD SDI • 3G-SDI: SMPTE424/425 Level-A • HD-SDI: SMPTE292M • SD-SDI: SMPTE259M-C
PROMPT IN	1x BNC, VS or VBS 1.0Vp-p/75Ω (loop through)
HD/SD OUT (1/2/3)	6x BNC, 3G-SDI(1080p)/HD-SDI (1080/25p, 1080/25PsF, 1080i or 720p)/ SD-SDI selectable (Embedded audio available) • 3G-SDI: SMPTE424/425 Level-A • HD-SDI: SMPTE292M • SD-SDI: SMPTE259M-C
PIX/WFW OUT	1x BNC, 3G-SDI/HD-SDI (1080i or 720p)/SD-SDI selectable (Embedded audio available) • 3G-SDI: SMPTE424/425 Level-A • HD-SDI: SMPTE292M • SD-SDI: SMPTE259M-C
MIC OUT 1	1x XLR, 3-pin, 0dBm/ 600Ω
MIC OUT 2	1x XLR, 3-pin, 0dBm/ 600Ω
INTERCOM (HEAD SET)	1x XLR, 5-pin, 0dBu Max +15dB
REMOTE 1	1x 4-pin, 1.5Vp-p or 1x D-sub, 9-pin RS-232C (Switchable)
REMOTE 2	1x 4-pin, 1.5Vp-p
REMOTE 3	1x RJ-45
COMMUNICATION	1x D-sub 25-pin • INTERCOM 0dBm , 600 Ω at 4Wire 0dBu or -15dBu ,200 Ω at 2Wire (ENG, PD and PGM)
TALLY OUT (R/G)	1x D-sub 9-pin, Contact 24 Vdc, 10 mA
WFM CONTROL	1x D-sub 15-pin WFM 0-7, 0/5V
Power supply voltage	100 to 240 VAC 47 to 63Hz(with auto-sensing mode)
Mass	11 kg, 24.3 lbs. approx.
Dimensions	432 (W) x 88 (H) x 419 (D) mm, 2 RU
Operating temperature	0°C to 40°C, 32°F to 104°F
Power consumption	300W approx. (AC operation, including SK-HD1800, VF-402 and AUX POWER OUT 100VA)

CA-HF550 Fiber Camera Adaptor

CCU connector	1x-type HFOC female connector (LEMO Type) SMPTE-304M-type
Video transmission system	Fully digital, bi-directional, 10-bit, 4:2:2 sampling, SMPTE-424M
Intercom	1x channel, 5-pin XLR, channel selection, MIC on/off, volume
Program audio	2x, PGM audio level controls w/ intercom mix
Teleprompter power output	1x 5-pin, 230VAC, 100VA max, external prompter Tally drive out (depending on configuration accessories)
Microphones	Chnl2 Line or MIC level select (MENU), with phantom power on/off
Return video selector	2-channel, 4-input (Chnl2), return video select switch
Video Outputs	2x 3G/HD-SDI out (1080p50/59.94, 1080i50/59.94), shared with Return/Prompter out (1080i50/59.94)
Power input	1x XLR 4-pin, 12VDC power input (male)
Mass	2.2kg, 4.8lbs. approx.

Studio Adaptor SA-1100

Power Consumption	2.0W approx. (excluding Lens, Viewfinder, Camera, DC output)
Mass	16.5kg, 36.4lbs approx. (excluding Lens, Viewfinder and Camera)
DC output	DC12V±10% MAX 2.5A DC5V±10% MAX 0.8A
Operating temperature	-10 °C to +45 °C, +14 °F to +113 °F
Dimensions	320(W) x 344(H) x 525(D) mm approx.
Operating humidity	30 to 90 %RH
DC input	DC12V±10%

2-inch Color Viewfinder VF-L20HD

Display device	2-inch color TFT LCD (16:9)
Number of pixels	960 (H) x 540 (V)
Functions	Bright, Contrast, Peaking, knobs VR front-facing Diopter
Internal tally	Red / Green
Tally switch	Tally switch OFF, NORMAL, HIGH
Power Consumption	Approx. 5.0 W (at Heater-OFF) 6.5 W (at Heater -ON)

HDF-700H-S1 7-inch Color LCD Viewfinder

TV System	50/60Hz, 1080i/ 720p auto-switching
Construction	Metal chassis and mount 7-inch, color TFT-LCD, 1920(H) x 1080(V)
Display	6500°K with removable hood
Camera mounts	AT-750 / AT-90
Functions	Chroma, WF on/off, Marker-1/2 On/Off, Bright, Contrast, Peaking, knobs VR (front-facing), Power ON/OFF
Internal Tally	Red/ Green, Front-facing high brightness LEDs
Tally controls	Red, OFF/L/H Selectable
Dimensions	195(W) x 153(H) x 50(D) mm
Power consumption	12 W approx.
Mass	1 kg, 2.2 lbs approx.

CU-HD550 Camera Control Unit

Genlock	1x BNC, B-BST 0.45Vp-p/75Ω (loop through) HDTV tri-level sync 0.60Vp-p/75Ω (loop through)
Digital Return 1/2	2x BNC, 3G SDI or HD SDI or SD SDI Shared with Prompter (3G SDI or HD SDI or SD SDI)
Communication Intercom PGM R/G TALLY	1xD-sub 25-pin,Incom,Tally 0dBm / 600Ω at 4Wire, 0dbu or -15dbu / 200Ω at 2Wire 0dBm / 600Ω Contact or DC supply
Video Outputs	6x BNC, 3G-SDI, HD-SDI, SD-SDI Selectable (Embedded 2-Ch audio available) 3G-SDI SMPTE424/425 Level-A HD-SDI (1080i, 720p) SMPTE 292M SD-SDI SMPTE 259M-C
MIC OUT 1	1x XLR, 3-pin, 0dBm/ 600Ω
MIC OUT 2	1x XLR, 3-pin, 0dBm/ 600Ω
Remote 1	1x 4-pin, 1.5Vp-p
Remote 2	RJ-45, LAN
Power supply voltage	100 to 240VAC 47 to 63Hz(with auto-sensing mode)
Maximum fiber cable distance	1 km (with utility power) 4 km (without utility power) 10 km (single mode fiber, with external camera power)
Operating temperature	0°C to 40°C, 32°F to 104°F
Dimensions	482(W) x 88(H) x 419(D) mm
Power consumption	300W approx. (AC operation, including SK-HD1800, VF-L20HD and AUX POWER OUT 100VA)
Mass	10kg, 22lbs

These Specifications are subject to change without notice.

DIMENSIONS (SK-HD1800 with CA-HF1300)

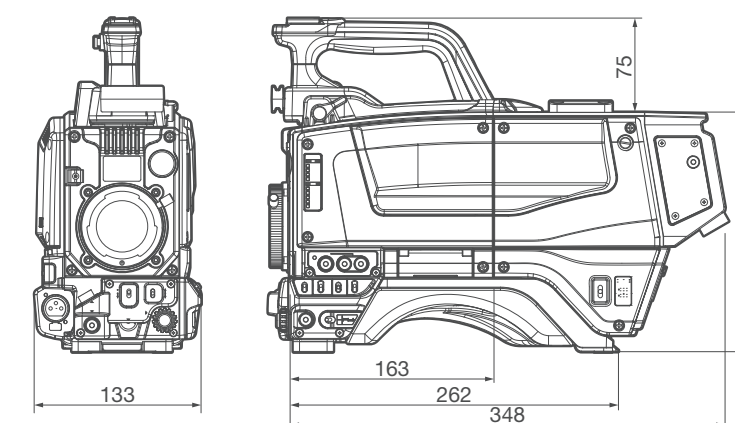

DIMENSIONS (RU-1500JY)

