

# KOKUSAI DENKI

## Full HD HD-SDI Camera **KP-HD1005W**

Full HD / CMOS / 0.015lux



- **High Definition**

High definition and wide viewing angle by full HD images

- **High Sensitivity**

1/2.8 type High sensitivity CMOS sensor

- **Digital Noise Reduction**

Motion adaptation reduces the generation of noise due to gain amplification

- **Defog**

The function adjust the image which is hard to see by haze or fog, and it can correct it clearly

- **Wide Dynamic Range**

The function capture images that can be recognized from dark areas to bright areas in the scene with a large difference in brightness

# Main Specifications

Characteristics	
Imaging method	HDTV(16:9) 1080 29.97p/25p
Imaging device	1/2.8 CMOS (RGB Bayer color)
Total pixels	1936(H) x 1120(V)
Effective pixels	1936(H) x 1100(V)
Sync system	Internal
Video SDI output	SDI HD-SDI/ HD-VLC* 0.8Vp-p/75Ω BNC type Output format: 1080(1080 59.94/50i, 29.97/25p) <small>* Dedicated multiunit MU-HD series (option) is necessary for HD-VLC mode.</small>
Video VBS output	Analog VBS (selectable PAL or NTSC) 1.0Vp-p/75Ω BNC type
Minimum illumination	0.015 lux (COLOR, F1.2 AGC:66dB, Gamma: High) 0.001lux (B&W, F1.2 AGC:66dB, Gamma: High)
S/N ratio	More than 50dB
Resolution	Horizontal resolution More than 800 TV line
Operational	
AGC	PRESET GAIN (0 to 66dB, approx. 1dB step setting) AGC LIMIT (MAX GAIN 0 to 66dB, approx. 1dB step setting)
Electronic shutter speed	PRESET = 1/30(1/25), 1/60(1/50), 1/100, 1/250, 1/500, 1/1000, 1/2000, 1/5000, 1/10000, 1/15000, 1/37500(1/31250) seconds
Sensitivity up	AUTO 2/ 4/ 6/ 8/ 10/ 12/ 16/ 32/ 60 times MANUAL 2/ 4/ 6/ 8/ 10/ 12/ 16/ 32/ 60 times
Haze correction (DEFOG)	OFF/ AUTO/ AUTO-HIGH
Day & night function	IR Cut Filter/ dummy glass switching mechanism
White balance control	Auto / One Push / Manual: Normal (2500K–8000K), Special (2300K–10000K)

## External dimensions

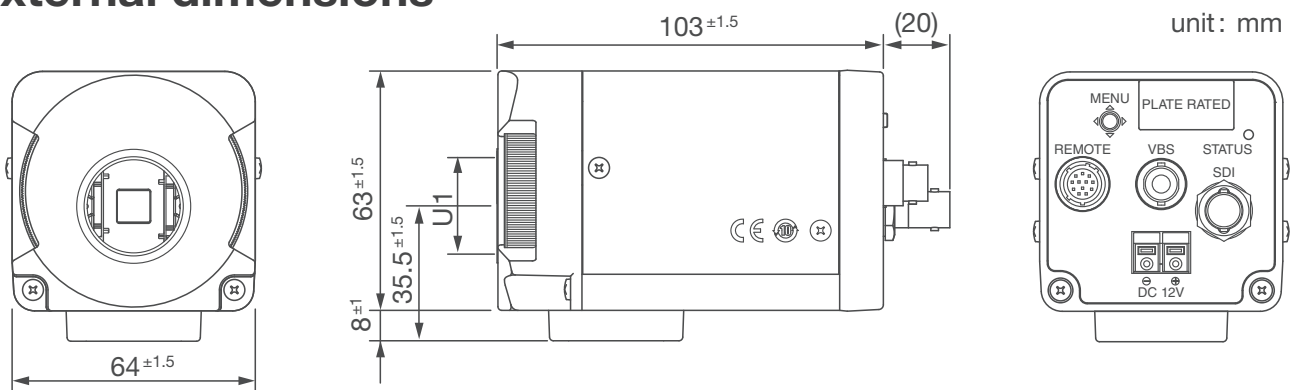

These Specifications are subject to change without notice.

**CAUTION** : To ensure safe operation, please read the instruction manual before using this product.

### KOKUSAI DENKI Electric Inc.

URL : <https://www.kokusaidenki.co.jp/global/en/index.html>  
32, Miyuki-cho, Kodaira-shi, Tokyo 187-8511, Japan  
Phone : +81-42-322-3111, Fax : +81-42-322-3303

### KOKUSAI DENKI Electric Asia Pte. Ltd.

URL : <https://www.kokusaidenki.com.sg>  
9 Tampines Grande, Asia Green, #02-00, Singapore 528 735  
Phone : +65-6911-6794

### KOKUSAI DENKI Electric America, Inc.

URL : <https://www.kokusaidenki.us>  
**Headquarters**  
104 Feeding Hills Road Southwick, MA 01077, U.S.A.  
Toll Free : +1 (833) 227-1658,  
Phone : +1 (669) 207-5038

**West Office**  
11258 Monarch Street, Unit H  
Garden Grove, CA 92841, U.S.A.

**West Sales** Phone : +1 (516) 682-4448  
**East Sales** Phone : +1 (516) 682-4445  
**Midwest Sales** Phone : +1 (516) 682-4450

### KOKUSAI DENKI Electric Europe GmbH

URL : <https://www.kokusaidenki.eu>  
**Frankfurt Head Office**  
Siemensstr. 9, D-63263 Neu-Isenburg, Germany  
Phone : +49 (0) 6102-8332-0, Fax : +49 (0) 6102-8332-499

**London Office**  
Orion House, Bessemer Road, Welwyn Garden City, Herts, AL7 1HH, UK  
Phone : +44 (0) 7808 330195

### KOKUSAI DENKI Electric Linear S/A

URL : <https://www.kokusaidenki.com.br>  
Avenida Frederico de Paula Cunha, 1001 - Maristela  
Santa Rita do Sapucaí - MG - Brasil - CEP: 37540-000  
Phone : +55 (35) 3473-3473, Fax : +55 (35) 3473-3474