

KOKUSAI DENKI

Full HD HD-SDI Camera

KP-HD2005R-S5

Full HD / CMOS / 0.009 lux / NIR Sensor



- Full HD 2.38 mega-pixel 1/1.9" high sensitivity CMOS image sensor.
- Standard C-mount lens permits use of a wide range of long zoom lenses.
- CMOS sensor produces HD pictures at 30/25 fps, progressive scan output.
- Ultra low-light capability at 0.009 lux
(COLOR, F1.2, AGC 75dB, GAMMA HIGH, SEN UP:OFF)
- More than 60dB S/N
(HD-SDI & VBS outputs, AGC 0dB, DETAIL -128, GAMMA OFF)
- Ultra-high sensitivity NIR Sensor Technology. (B&W)
- Camera offers focus output function. When used with KOKUSAI DENKI's IF-PCB interface, it dramatically improves zoom lens Auto Focus speed & accuracy.
- Single cable connectivity for power, video via Coax Cable.



Rear Panel

Motion Stabilizer

Motion Stabilizer (with KOKUSAI DENKI's VG-2000PCB)
2000mm Zoom Lens x60 Zoom



Before

After

Long Range, Low-Light Capability

2000mm zoom lens. 1/2 mile distance, low light

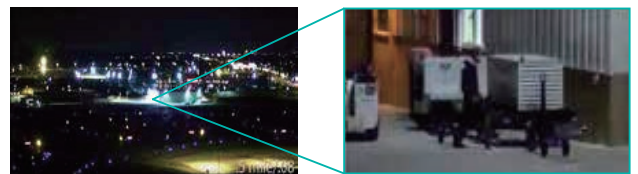

No Zoom

x60 Zoom

Real Time Heat Haze Correction

Heat & Haze correction, 2000mm Zoom Lens
x60 Zoom (with KOKUSAI DENKI's VG-2000PCB).



Before

After

Fog & Smoke Reduction

Adaptive Defog. B&W with Visible Cut (LENS Option)
Filter allows camera to see through fog in real time.



OFF

ON

Main Specifications

KP-HD2005R-S5	
Imaging Device	1/1.9 CMOS (RGB Bayer color)
Total pixels	1952(H) X 1241(V) 2.4M pixels
Effective pixels	1937(H) X 1097(V) 2.38M pixels
Imaging System	Progressive 30 fps / 25 fps (P-type)
Sync system	Internal
Video output	HD-SDI (SMPTE292M) & Analog VBS (selectable PAL or NTSC)
Video format	HD-SDI: 1080/59.94i, 1080/29.97p, 1080/50i, 1080/25p
Minimum illumination	Color : 0.009 lux (F1.2 AGC:75dB, Gamma: High, SEN UP OFF) B&W : 0.0005 lux (F1.2 AGC:75dB, Gamma: High, SEN UP OFF) *3200K Tungsten lamp used for testing
S/N ratio	More than 60dB
Resolution	Horizontal resolution more than 800 lines TV lines

OPERATIONAL	
AGC	OFF / Auto (Max Gain 75dB, fog OFF, Max Gain 42dB, fog ON)
Electronic shutter	OFF / AES / Manual (1/30 to 1/100000 sec)
Electronic sensitivity (SEN UP)	OFF / Auto (Max 60 times) / Manual (2 to 30 times)
Fog Reduction	OFF / ON / Auto (1 to 128 levels)
Day & Night (W/B switching)	COLOR / B&W / Auto (ICR)
BLC	OFF / ON (photometry area with ROI capability)
White Balance	Auto : ATW Manual : Manual (2500K – 8000K)

External dimensions

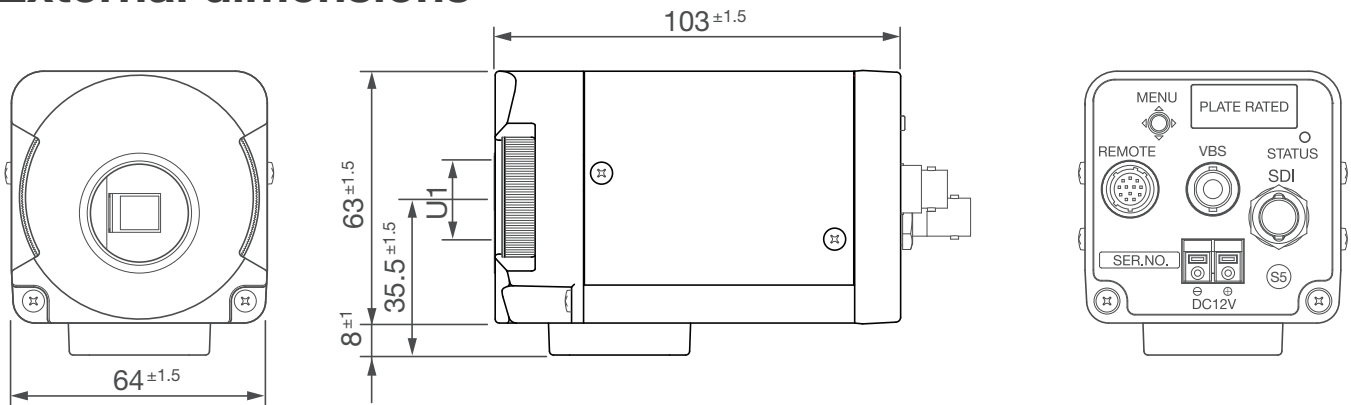

These Specifications are subject to change without notice.

CAUTION : To ensure safe operation, please read the instruction manual before using this product.

KOKUSAI DENKI Electric Inc.

URL : <https://www.kokusaidenki.co.jp/global/en/index.html>
32, Miyuki-cho, kodaira-shi, Tokyo 187-8511, Japan
Phone : +81-42-322-3111, Fax : +81-42-322-3303

KOKUSAI DENKI Electric Asia Pte. Ltd.

URL : <https://www.kokusaidenki.com.sg>
9 Tampines Grande, Asia Green, #02-00,
Singapore 528 735
Phone : +65-6911-6794

KOKUSAI DENKI Electric America, Inc.

URL : <https://www.kokusaidenki.us>

Headquarters

104 Feeding Hills Road Southwick, MA 01077, U.S.A.
Toll Free : +1 (833) 227-1658,
Phone : +1 (669) 207-5038

West Office

11258 Monarch Street, Unit H
Garden Grove, CA 92841, U.S.A.

West Sales Phone : +1 (516) 682-4448

East Sales Phone : +1 (516) 682-4445

Midwest Sales Phone : +1 (516) 682-4450

KOKUSAI DENKI Electric Europe GmbH

URL : <https://www.kokusaidenki.eu>

Frankfurt Head Office

Siemensstr. 9, D-63263 Neu-Isenburg, Germany
Phone : +49 (0) 6102-8332-0, Fax : +49 (0) 6102-8332-499

London Office

Orion House, Bessemer Road, Welwyn Garden City, Herts,
AL7 1HH, UK
Phone : +44 (0) 7808 330195

KOKUSAI DENKI Electric Linear S/A

URL : <https://www.kokusaidenki.com.br>

Avenida Frederico de Paula Cunha, 1001 - Maristela
Santa Rita do Sapucaí - MG - Brasil - CEP: 37540-000
Phone : +55 (35) 3473-3473, Fax : +55 (35) 3473-3474